

## Analysis and Development of a Self-Dimming Module for Road Traffic Signals

Nur Diyana Mohd Hamidi<sup>1</sup>, Siva Kumar Subramaniam<sup>2</sup>, Mazran Esro<sup>2</sup>, Ismail Yusuf Panessai<sup>3</sup>

<sup>1</sup> Department of Electronic Engineering, Faculty of Electronic and Computer Engineering, Universiti Teknikal Malaysia Melaka. Melaka, Malaysia.

<sup>2</sup> Advance Sensors & Embedded Controls System (ASECS), Centre for Telecommunication Research & Innovation (CeTRI), Fakulti Kejuruteraan Elektronik dan Kejuruteraan Komputer, Universiti Teknikal Malaysia Melaka. Hang Tuah Jaya, 76100 Durian Tunggal. Melaka, Malaysia.

<sup>3</sup> Department of Computer Science and Digital Technology, Faculty of Computing and Meta Technology, Universiti Pendidikan Sultan Idris. Tanjong Malim, Malaysia.

### Article History

**Received:**  
30.01.2023

**Revised:**  
27.02.2023

**Accepted:**  
18.03.2023

### \*Corresponding Author:

Siva Kumar Subramaniam

### Email:

siva@utem.edu.my

This is an open access article,  
licensed under: [CC-BY-SA](https://creativecommons.org/licenses/by-sa/4.0/)



**Abstract:** Nowadays, we often see more and more of the various types of lights in urban areas, especially in road areas, either regarding the use of traffic lights or streetlights that serve as guides and signals to maintain road safety. Typically, the lamps use LED-based lamps as they can increase the rate of high savings. This LED conceptual light helps reduce energy wastage by using less power and reducing the consumption of heat and is suitable for day-to-day operation. The addition of ordinary LEDs to self-dimming systems based on the intensity of light around is more likely to increase the savings rate and is more environment-friendly. The scope of this research includes analytics data from the use of standard traffic lights and LED signal lights that are self-concept in dimmer systems. This research uses the IoT concept that is applied to the traffic system and uses solar energy which is indeed renewable natural energy and can affect the green earth concept to the traffic control system on the road.

**Keywords:** IoT, LED-Based Lamps, Traffic Lights.



## 1. Introduction

The traffic light is one of the traffic infrastructure facilities designed to control traffic at every intersection of roads so that vehicle movement can move smoothly. This traffic light function is to prevent the collisions between road users by sending signals to road users using three different colours. These three colours give different signals consisting of green colours that mean go, amber colours indicate ready to stop, and red mean stop. Through the three colours control of this traffic light, any incidents can be avoided, and road traffic operates smoothly and systematically. Besides, the traffic light also allows pedestrians to cross the road safer by pressing the push button and cross the over when green light for pedestrians was turned on.

There are various types of lamps used in everyday life to make it easier for us to see things more clearly as well as the traffic light system. Traffic light consists of several types of bulbs where the specification for each bulb is different. Some of traffic light use halogen bulbs and incandescent bulb, but now, at this point, LEDs have highly demand [1] in the usage of a traffic light. Not only for a traffic light but are LEDs also used in everyday use for example at home, but working area and other places around us as LEDs are also very reliable when compared to other bulbs. Usually, we are about to minimise the cost of the electricity, especially in big cities area. Hence, LED is one of an alternative way to prevent the energy wasting in the use of lighting and produce low power which helps to save the cost of a traffic light in daily use. LEDs are also more environmentally friendly and more sustainable to the environment. The most important things are the LED can stand for an extended period while helping to reduce the cost of maintenance [2].

The reason why nowadays the halogen bulb and incandescent are replaced with the LED bulb is the ability of LED to operate in cold condition and able to stand for an extended period as mentioned before [3]. LED can work about 50 000 hours which are 13 times longer than the period of a halogen bulb and 42 times longer for the life-span of incandescent bulb [4]. Also, this LED capable of reducing the usage of power consumption and at the same time tend to give more energy to the system. As we can see, the LED are sustain and environmental-friendly as it does not consist of any mercury, any harmful gasses that can affect the user compared to halogen and incandescent as both bulbs produced infrared and also ultraviolet that can give damages to the fabrics. We can purchase the LED in various types of white and other colours as it has good lighting and much brighter compared to other bulbs. Through all the characteristics we believe, LED is the best to be applied to the traffic light system.

Apart from that, LED also has various types of the array and basically, we often see the high flux LED array and dot matrix LED array. First, we go through the high flux LED which uses only 8 LEDs on display for a traffic light. It consists of a base substrate, and a flip-chip LED with a transparent substrate and also cover substrate [5]. The high flux LED is surrounded by diffuser which located between the Fresnel lens and LED and horizontally installed on the heat sink. The heat sinks help to move the heat released by the LED to the surrounding. This high flux LED array also comprises one centralised right angle prism with a square horizontal cross-section [6]. The tubular diffuser that placed surrounding the LED has a frosted surface which ensures the emitting light from the LED. Same goes with a tubular diffuser, fresnel lens also installed to the surroundings LED as the light from LED will pass through the diffuser and the lens gives the horizontally uniformly light.

For dot matrix LED array, it seems similar to the high flux LED display but have more LED comprises about 100-200 LEDs. This creation is circuitry control as it allows the current to the LED continually. The dot matrix consists of an 8X8 grid, and this display is referring to the circular lens that mounted in front of the LED on the base of traffic light [7]. The LED also will link to the heat sink and sealed with glass material to prevent the LED from dying. The glass material used for longer the life-span for LED as it protects the LED from oxygen gas, exposed to the humidity and due to other factor make led easily damaged [8]. Besides, LED must be secured with thermal contact arrangement or heat sink as it allows to remove the heat produced by the LED through the bottom surface of the LED. The criteria for high flux and dot matrix are quite similar. They have a little bit different on the number of LEDs used on the display panel.

Dimming process is one of the effective ways as it helps to reduce power consumption and make the lighting in higher performance and we are about to use the dimming method to the LED traffic light system as LED is able in dimming process. During dimming process, LED can increase the brightness in having high or low brightness according to the intensity of light at the surrounding and do not lose efficiency as the output for voltage and current still the same [1]. The dimming process

can decrease the heat produced by the bulb as the higher temperature shall reduce the life-span for LED [1]. The method for dimming process is the pulse width modulation (PWM) as it turns on and off the low voltage at a higher frequency. The concept used is the duty cycle in the percentage that describes the time for the digital signal over a period where the square waveform considers as “on time” when achieved the high sign. The bulb gives higher brightness if the on-time below 5% and full dim when on time over than 95% [9].

This project is proposed due to the LED traffic light because the self-dimming can help in reducing the power used as it minimises the heat produced by the LED. As nowadays, we can see the size of the population is increased. As the population increases, new places are opened to accommodate this population and the opened placements will add more traffic lights which will release more heat to the surrounding. More traffic light release more heat, as to overcome the heat problem the dimming LED is introduced. This project can reduce the heat released as it can save the global warming issues to our country.

Besides, this LDR used in traffic light can control the LED brightness due to the light intensity from the surrounding. This can help the road user who has a problem with a glare-visually impaired vision. For an instant, during the night trip, the LED will lower the brightness and prevent the user from having a glare vision as the driver can easily see the signal appears on traffic light display in short distance. Apart from that, the dimming module also can decrease the cost of electricity that the government has to pay for daily use which they did not have to spend a lot of money to the traffic light usage as the power released and energy consumed can be reduced through this research work.

## 2. Literature Review

### 2.1. Concept of Dimming System

The dimming is about the decreasing the brightness of the light for some purpose in reducing the power of electric usage, perform perfect visibility and reduce the dazzling issue by road users [10]. The dimming systems are widely used and increasingly being implied in lighting and come from various techniques and technologies to reduce high levels of light to a minimum level.

The proposed work applied the dimming system to road traffic signal as to minimise the usage of energy for a traffic signal. Besides, it also improves the problems faced by the road users on the road that having glare problem when looking at the traffic signal with high brightness at night. The system will help by giving the normal brightness during the daytime and start to decrease the brightness when having lower light intensity especially when night time. Besides, the system helps to increase more brightness when detecting any presence of water, especially when having heavy rain.

By this system, the light can be increased as it can be seen clearly by road user due to heavy rain. This system more toward the saving power usage as the dimming during the night will use less power compare than daytime. The authors of previous work [11], also have same objectives for their last system. The previous work [10] uses ALS as the input to control the brightness of light as it converts the ambient light into the signal. The working system using ALS sensor is the light intensity produced by LED is getting higher as the sensor senses more ambient light from the surrounding. It also switches the level of brightness at a fast rate as it connected straight away to an auxiliary supply

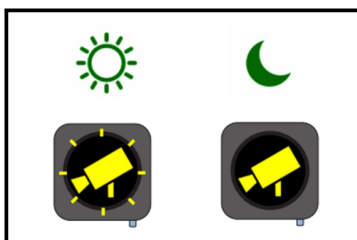

Figure 1. Auto-Dimming for LED Traffic Signal

As stated, the dimming use phase cut which applied to incandescent lamp where the voltages of RMS is reduced and decrease the value for current and gives the lower brightness of the light [12]. The AC signal comes out with full wave signal waveform, and by using phase cut technique, it will change the waveform which results in the half waveform and produces minimum light compared to

full wave AC signal. The LED also use the AC phase cut and dim the light according to the pulse width when stated at “full on” sign, but the LED might not give full output as it is controlled by pulse width from AC signal. Some system they believe dimming concept using PWM dimming will provide more advantages as they will gain more precise dimming and also reliable to be applied in digital control technology [13].

According to Fongbedji et al [13], PWM used the low-voltage dimming to switch between on and off at high frequency. The output light will give the maximum brightness if the on time is below than 5% and perform full dim when the on-time reach above 95% as the voltage that delivered to the lamp depends on the length of the duty cycle. The previous work [14] uses PWM circuit made up from the 8-bit counter and 8-bit comparator where the input is connected to duty cycle, and the input comparator connect to counter. The concept is when the counter value is lower than value for duty cycle; the comparator will trigger the high output. The amount of duty cycle is set to be a higher value to maximise the turn-on time. The comparator would present no production if the counter and duty cycle value were in the same amount. The figures below show the two different waveforms, and different brightness as the higher percentage of duty cycle gives higher brightness

The proposed work from [15], the techniques of dimming is applied through the temperature protection mode and a power-saving mode. The value of temperature work inversely proportional to the luminance of the light as the higher temperature reading cause the luminance to operate with lower output. The system detects any presence of human while the designed circuit provides the temperature protection mode so it can detect the temperature from the LED. There are two sensors used in this research as sensor 1 and sensor two which represent the temperature protection mode and power saving mode respectively. The dimming works on sensor two as the power saving is active when the switch of the sensor is set at a higher value. Then, the sensor that detects will presence of a human is triggered when detecting any motion that passed by the lamp and gives 100% light output. Then after a few minutes, if the motion sensor is not activated, the power saving mode will reduce the light output to ensure the saving of power usage. The luminance of the light keeps on decreasing when there is still no detection of any movement by a motion sensor.

## 2.2. Microcontroller Used for Traffic Light System

The traffic light can be controlled by different types of the microcontroller as stated by the authors of the previous research. For this proposed traffic light system, the microcontroller used is the Arduino UNO R3 as it is reliable to control this dimming system and gives the desired output. It is easy to conduct as the Arduino language is not too complicated to understand for starter user. After all, Arduino also has high demand and widely used for other electronic things as the Arduino support the IoT platform.

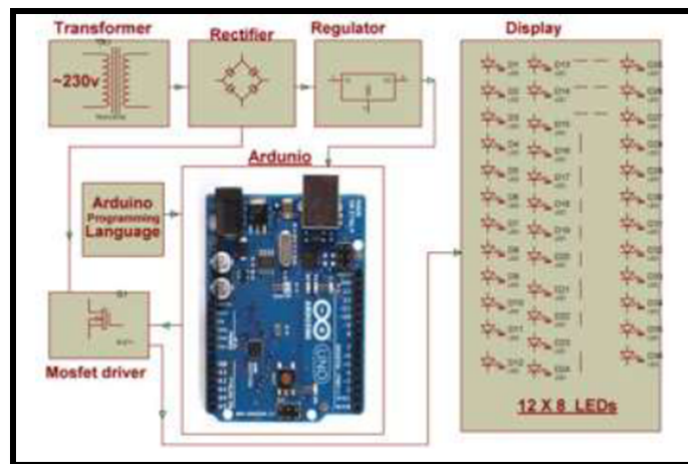

Figure 2. The Arduino UNO Microcontroller and MOSFET Device

The research by Mishra et al [16] using Arduino and rectified power supply and also the MOSFET device where the LDR sensor and photoelectric sensor are the input for the Arduino and produced the output according to coding programmed in Arduino. The dimming system is using PWM as Arduino received the command to present on and off state. The MOSFET has similar function with a relay which it switches whether it is on or off for the system. The Arduino is used as it is easy to use for both hardware and software. For the dimming mode, the LDR will detect the ambient light to discriminate the condition between night and daylight. The data from LDR will be sent to Arduino and it only active the photoelectric sensor at night as this sensor will detect the presence of a vehicle and make the Arduino to on the light.

The Arduino also used in work as mentioned by Husin et al [17] but with a different type of Arduino which is Arduino Atmega 328P as this module is compatibility for this system. The Arduino has four inputs which are clock, power, and vector input and water sensor. The feedback received by Arduino Atmega 328P will control the system and function as the desired system. All role can be covered by this microcontroller to switch the on-off power switch for this system. Besides, the Arduino provides Analog to Digital Converter (ADC) without need any requirement of location access. Instead of using Arduino, PIC 18F4520 is used for dimming system as it is a programmable microcontroller. Due to [5], this microcontroller controlled two conditions which are the temperature protection mode and power saving mode.

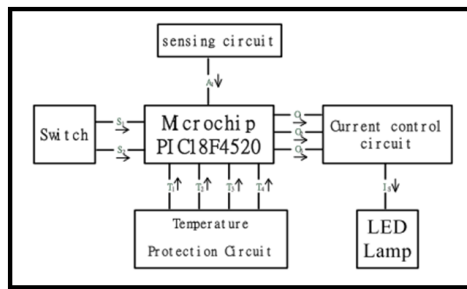

Figure 3. Circuit Architecture Controlled By PIC Controller

A PLC is a recently used to control the traffic light system as this microcontroller can be programmed. The PLC can easily control the sequences of a traffic light can operate without the need for human energy and help. Due to work system by Hsia et al [14], the automated traffic light is proposed for road user's safety while having a road construction as the PLC is used as the primary controller to change the existing manual traffic control that can lead harmful to human. The motion sensor used will locate any movement of vehicles and send the data signal to the central controller meanwhile the PLC will have an interaction with the minor system that works under PLC to proceed with the next action.

### 2.3. Types of Traffic Light Array Display

There are various types of a display board for a traffic light for each country. The traffic light in Malaysia uses either high flux LED array or dot matrix LED array.

#### 2.3.1. High Flux Traffic Light Display

The LED array of traffic light system may include high flux LED array and dot matrix LED array. Both LED array gives the signal to the road users to control the traffic flow. The high flux LED contain a few numbers of LED and mainly used eight LEDs to light up the traffic light while the dot matrix uses a lot of LEDs. The high flux LED with eight LEDs able to provide the perfect lighting that can be seen by road users. The issue here, the traffic light will get dimmer when two or three led burns. Otherwise, the dot matrix will not affect the brightness of LED as it will remain the light intensity if a few LED is burned as it contained a lot of LED that can cover the broken one. But usually to save the cost the high flux is more preferred as it is cheaper than dot matrix LED.

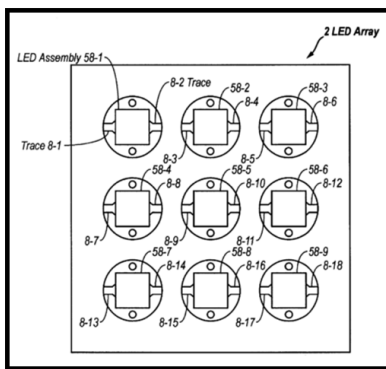

Figure 4. Position of LED for the High Flux Traffic Light Display

High flux LED array primarily used in the application of the street lighting, traffic light and other more application. The invention of this LED array contains metal substrate, a dielectric layer above the metal substrate and electrically conductive trace on the dielectric layer [18]. The LED consists of the flip-chip type with a transparent substrate to emit the light. Two parts of the substrate are connected to both charges positive and negative electrodes as the base substrate can handle high current and heat that produced by LED. A cover substrate with white and high reflective material has used that consist of the hole in the centre area to increase the light output [5]. The hole is filled with transparent resin or epoxy fills to build a convex lens so it can cover the light from the LED.

### 2.3.2. Dot Matrix Traffic Light

For dot matrix comprises with the arrangement of 8x8 grids and the negative and positive leg of LED shared the same terminal [10]. The dot matrix LED array is mounted to a heat sink which allows the direct light to flow through Fresnel lens and the diffuser. The individual LED is placed in thermal contact arrangement, and the heat sink as the heat of LED can be dissipated through the bottom surface of the light emitting diode [7]. The advantages of this dot matrix, in a way to extend the lifespan of LED, every single LED is sealed with glass material that diffused with lower temperature as to protect the LED from exposed to the oxygen, humidity and other contaminants which can reduce the LED lifespan. Besides, the front surface of heat sink provides a central opening that can allow the light from LED to pass through. The Fresnel lens has direct contact with the lens and the housing interior and potentially facing the light diffuser and the light source. The pattern and material of dot matrix LED are quite similar to the high flux, but the most preferred and quality LED is the dot matrix LED array as it can stand longer compare to high flux and at the same time can cut the cost of maintenance work.

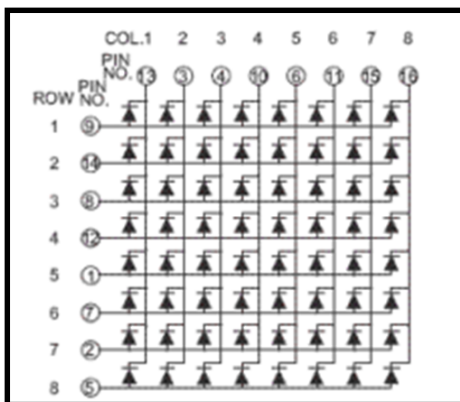

Figure 5. Position of LED for the Dot Matrix Traffic Light

### 3. Methodology

The whole prototype is roughly briefing the guidelines of the prototype as the work can be done smoothly. Figure 6 shows the flowchart for the overall prototype.

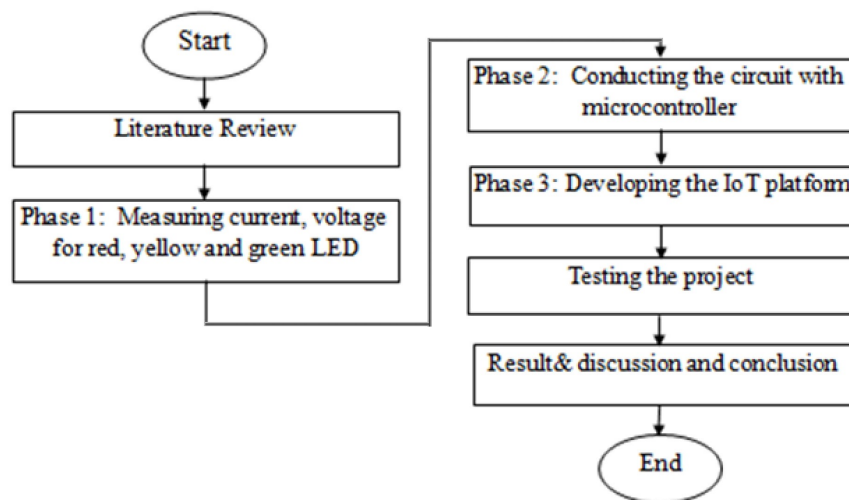

Figure 6. Flowchart for the Overall Prototype

The reading of literature review from other research work that related to this prototype gives some theory that can apply to this prototype. Then, for the first stage, the current for each colour of LED is recorded and continued by conducting the Arduino connections with all input and output for traffic light system. The next action is applying the IoT platform to connect the system to an internet connection and able to send the data through the application. The prototype is tested to ensure that the whole system is entirely working.

- **Phase 1: Measuring current, the voltage for red, green and yellow LED**  
The red, yellow and green LEDs are tested on the testing board to measure the current and different voltage of each colour LED. Then, the resistor and LED are soldered to the display board and all LED must be functioning before the current for LED is measured again. The data is collected from the conducted experiment and the theoretical also been calculated by using Ohm's Law.  
The LED is placed on the testing board and powered up by 5V and 12V. The testing board is used to test the brightness and the suitable resistor for each display board before the resistor and LED is transferred to the display board. The current is measured using clamp meter, and the data is recorded in the table. Then, the LED and resistor are soldered to the display board, and again the current is measured, and all information is recorded.
- **Phase 2: Conducting the circuit with a microcontroller**  
Next step is combining the input, output, and Arduino for the complete circuit on a breadboard. The LDR and rain sensor are used as input to detect the brightness and rain condition at the surrounding of the traffic light. The luminance detected by LDR will determine the voltage applied as shown in the figure below.  
The LED display is powered up by 5V if the luminance value for LDR is 100 and below as it showed as night condition and the voltage will be switched to 12V when the reading of luminance is above 100 which is the traffic light is in the daytime. The 5V during the night will automatically turn to 12V if the rain sensor detects water as to increase the brightness of the LED.
- **Phase 3: The Developing for IoT Platform**  
For this phase, the prototype will be implementing with IoT which is it can be connected to the Internet. The circuit is connected with Wi-Fi module which is able the Internet connection. Through this implementation, the traffic light system will send the data to the main Traffic Centre to inform the performance of traffic light through the created application. If the traffic

light did not function well, the LED indicator would keep on blinking while the data will be collected and send through Wi-Fi and the message or email will be sent to the maintenance workers to do some services for the traffic light.

- Testing the Prototype

After done with all three phases, the proposed system is ready to be tested. The proposed method is supplied by 5V and 12V and controlled by LDR sensor to apply dimming concept into this traffic light system. The system is maintained using with power supply from 12V during the daytime.

When the luminance value detected by LDR sensor is decreasing, the relay will switch the power supply from 12V to 5V to put the system in night state. When the water is detected while 5V supplies the system, the rain sensor is triggered, and the relay switches back the power supply from 5V to 12V to increase the brightness of the traffic light system.

If the LED traffic light is not fully functioning, the LED indicator will keep on blinking, and the data will be sent to Thingspeak, and the alert message or email also is sent to the maintenance workers to speed up the service of the traffic light so that the lamps are fully functional.

The prototype is tested to make sure the traffic light is functioning well, any short circuit, and non-functioning components are troubleshoot until the traffic light is working as a proposed system.

#### 4. Finding and Discussion

##### 4.1. IoT Platform

The current is sent to the Thingspeak through the Internet connection, and when the value for current is decreasing about 60%, the data can be seen through the Thingspeak. For this proposed system, an application is created to ease the staff maintenance to check the traffic whether it is functioning well or need to be serviced. The email will be sent to the service centre.

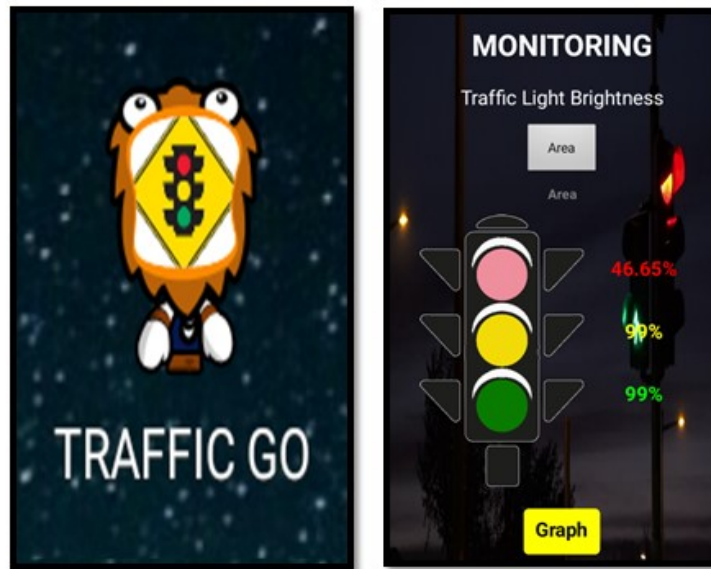

Figure 7. Traffic Go application for the Traffic Light System

The Traffic Go is an application created to read the current value from the traffic light. Based on the use, if the current for LED is below than 60%, then the traffic light inside the application will be blinking to alert the maintenance to do some services for the broken LED.

The staff maintenance will receive an email which to make them alert to this issue. The email will include the percentage of current for each LED and state the location of a traffic light to ease the



service process and also state the date and time so that broken LED can be recorded to their system. The staff will receive the email.

#### 4.2. The Luminance Captured by LDR Sensor

The LDR sensor is connected with Arduino to read the value for light intensity at the surrounding area with the small circuit. The reading is recorded and tabulated in data for lux reading against time. The maximum value for lux reading is 1023.

Table 1. Lux Reading against Time

Time	Lux Reading	Condition
6 pm	703	daytime
8 pm	37	night
10 pm	30	night
12 am	47	night
2 am	33	night
4 am	39	night
6 am	51	night
8 am	552	daytime
10 am	891	daytime
12 pm	921	daytime
2 pm	934	daytime
4 pm	918	daytime
6 pm	821	daytime

Table 1 shows the lux reading recorded for a few hours with two conditions stated in the table which are in daytime and night. The situation will indicate as daytime if the lux reading is higher than 100 and at night state if the reading is below than 100. The lux reading is affected due to the less light intensity captured by the LDR sensor and results in the lower value. The condition will determine the voltage needed for this traffic light system as the 12V will be used during the daytime and switch to a lower voltage which is 5V at night.

#### 4.3. The Current Reading for LED Traffic Light on Testing Board

The current reading is recorded for both power supply from 5V and 12V. The data gained is taken and tabulated in Table 2.

Table 2. Current and Power for Each Colour of LED

Voltage		Different colour for LED Traffic Light		
		Red	Yellow	Green
5V	Current(A)	0.5000	0.5000	0.6000
	Power(W)	2.5000	2.5000	3.0000
	Power(kwH)	0.0025	0.0025	0.0030
12V	Current(A)	1.7000	1.7000	2.4000
	Power(W)	20.4000	20.4000	28.8000
	Power(kwH)	0.0204	0.0204	0.0288

Table 2 shows the difference between current usage and power consume by 12V and 5V when the LED is testing on the testing board, and the data indicates by using a bar chart. The current applied by 12V is almost half from if compared to the current supplied by 5V. However, for the power consumed by 12V is quite high than 5V which shows more power savings can be made at night. Besides, the significant result seen in the figure is due to the voltage value as the value of current is multiplied by the voltage used to get the power usage for this system.

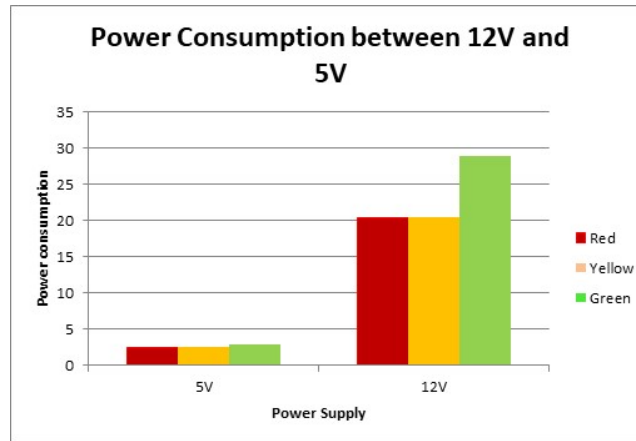

Figure 8. Power Consumption between 12V and 5V on Testing Board

#### 4.4. Discussion

After through all these chapters for the proposed dimming traffic light system, there are some issues and problems during the completion of this project. For phase 1: Measuring the current and the power for each colour of the LED for one traffic light pole. The LED was tested on testing before all LEDs were being moved to display board. For the testing board, the values of resistor used are  $330\Omega$  for the green LED and  $470\Omega$  for red and yellow LEDs. After placed all the LED, the testing board is powered by 5V and also 12V.

For proposed system, the traffic light will be power up by two different voltages which controlled by the reading of LDR sensor to determine day and night condition. The changes from 12V and 5V for the dimming concept are not able to be seen clearly as the brightness when using these two voltages is almost identical. This issue due to the resistor will limit the brightness of the LED to the maximum intensity when using the power supply from 5V. So, when the voltage is increased to 12V, the brightness almost reached the maximum brightness and caused a change of brightness is not very apparent. However, this change between 12V and 5V can be seen from current taken where the reading for 12V is two times higher than 5V same goes with the power consumed in this proposed system. As stated in Ohm's Law, the higher voltage will absorb more energy used for the traffic light.

Besides, the LDR is a sensitive sensor as the value for LDR can quickly drop from hundred values to two digits value and vice versa. Due to this, when there is a cloudy during daylight, the LDR detects a lower light intensity and a lux reading of less than hundred, it will cause the voltage to change from 12V to 5V during daylight hours. But this is not a big issue as cloudy conditions caused the environment to cope with lower light intensity and brightness generated from 5V powered traffic light still visible to road users. The road user's vision is limited when in a rainy state; it makes it difficult for the driver to see the traffic light more clearly. Hence, the rain sensor is applied as an input for this system and when in a rainy season, rain sensors will detect the presence of water and will convert and increase the brightness from 5V to 12V.

Next, the problem comes while handling the circuit for the traffic light system. The circuit connection is built on the breadboard first before transferred on PCB board. There is no problem while conducting the circuit on a breadboard, but when it moved to the PCB board, the system is not functioning anymore because the PCB board is not soldered neatly. The solder lead is not appropriately soldered between the copper and the component's leg. The connection is not connected

to the component and the make the system does not work. Then, the elements on PCB board were soldered again, and the circuit is tested one more time. During the testing process, the Arduino starts to not functioning, and PCB board also has a short circuit which caused the whole system is not operating. Then, another PCB board is fabricated again and solved this board issue.

The circuit is functioning for the dimming system, but sometimes the relay didn't switch the voltages due to the mounting IC ULN2003 with IC socket as the ULN is a driver circuit for the relay. This proposed system can connect to the Wi-Fi connection but need to set the connection that will be used first or else the Arduino will not function. The connection needs to be placed in the coding of Arduino language which includes the name for Wi-Fi and also the password to able the connection for the traffic light.

## 5. Conclusion

The dimming traffic light is rarely seen, and mostly the dimming concept is applied to the street light. The idea of dimming is aimed at reducing energy levels for the use of traffic lights in a daytime rate. Low voltage usage at night compared to daylight hours helps minimise power consumption and reduce heat. The first objective is achieved as the proposed system able to function in two different voltages due to the day and night changes. Besides, this dimming traffic light able to extend the lifespan of the LED as heat generated by traffic light has been reduced through this system. The LED can last longer if compared to other types of lamps but flammable if they are too exposed to intense heat. Hence, the low voltage at night will help reduce the heat which revealed to the LED. Some road is having a limited vision while driving especially at night as they are having dazzling by seeing the traffic signal. Hence, this proposed system is reducing the brightness rate and reduce the glare of the driver and able them to look at the traffic lights while providing the safety for the road users.

The heat generated from the use of traffic lights is capable of increasing heat in the environment and the heat generated from vehicles on the road as well as raising the temperature and asserting global warming issues. For the sustainability, the LED that reduces energy will help in decreasing the earth temperature as the installation of signal lights is increasing over time and also some heat reductions can be generated using the dimming of the system. In term of environmentally friendly, this system able the maintenance staff or workers under the installation of traffic lights to access to the data of traffic system to ensure the traffic light are fully functioning according to the proper brightness voltage. Also, the proposed traffic signals allowed the connection with internet and had its application to check the status of the traffic light easily and received an email for any service.

The proposed traffic signal is an idea for improving existing light traffic to better regarding power consumption that is used by traffic light during the operating system. However, the proposed method can have some innovation with some ideas to be applied in the future. For now, the traffic light is using two supplies for the one-day operation to minimise the power usage. For future work, the solar system can be used in this dimming system as the amount comes from the renewable energy during daytime and can make extra saving for the power needed by a traffic light. Besides, the uses of renewable energy source helps to drop the energy bills while generating its electricity from the solar system. The prices for solar panels may be quite high, but the solar panel has low maintenance cost for services as to keep the solar panel clean and to perform effectively.

## References

- [1] L. L. Turner, "Invention of the First Traffic Light," *sciencing.com*, April 25, 2017. [Online]. Available: <https://sciencing.com/invention-first-traffic-light-12955.html>. [Accessed: Dec. 12, 2022].
- [2] Anonymous, "LED Traffic Signals: Saving Money and Energy," Oct. 12, 2022. [Online]. Available: <https://www.yakimawa.gov/services/streets/led-traffic-signals/>. [Accessed: Dec. 12, 2022]
- [3] C. Hsu and P. Chang, "Evaluating Government Policy on Accelerating the Use of LED Lighting Products Using System Dynamics Modeling in Taiwan," *PICMENT 2012, Technol. Manag. Emerg. Technol.*, pp. 50–59, 2012.
- [4] S. Oca, "LED vs. Incandescent & Halogen," *superbrightleds.com*, 2017. Available: <https://www.superbrightleds.com/blog/led-vsincandescent-vs-halogen/707/>. [Accessed: Dec. 12, 2022].

- [5] A. F. Lindsay and B. L. Stamper, "(19) United States (12) Patent Application Publication (10) Pub. No.: US 2009 / 0323203 A1 If / I," vol. 1, no. 19, pp. 0–8, 2009.
- [6] Anonymous, "Cite a Website - Cite This for Me," Pdx.edu, 2017. [Online]. Available: <https://www.pdx.edu/nanogroup/sites/www.pdx.edu.nanogroup/files/2017%20Lab%203%20REff%20Controlling%20a%20Dot%20Matrix%20LED%20Display.pdf>. [Accessed: Dec. 14, 2022].
- [7] S. State and L. With, "United States Patent," vol. 1, no. 12, 2003.
- [8] P. Vanysek, I. L. Us, and H. S. Ricco, "(12) United States Patent," vol. 2, no. 12, pp. 2–9, 2005.
- [9] Waluyo, F. Hadiatna, A. Widura and P. Setiana, "Development and testing of a light dimming control using arduino uno," *International Conference on Science in Engineering and Technology (ICoSiET 2020)*, vol. 1212, 2022.
- [10] A. Vaishnav and R. K. Nishad, "Automatic Dipping System for Vehicles Headlight," *Journal of Mechanics Engineering*, vol. 1, no. 3, 2015.
- [11] Anonymous, "History of the Traffic Light," 17 April 2014, [Online] Available: <http://lazybookreviewer.blogspot.com/2014/04/the-history-of-traffic-light.html> [Accessed: Dec. 10, 2022]
- [12] C. Dilouie, "Dimming HID lamps can produce significant energy," vol. 2, no. 12, 2012.
- [13] M. Fongbedji, M. Bouya and N. Krami, "Smart city vision: optimization by coupling Street lighting and Led Based traffic signs," *ICEMIS'21: The 7th International Conference on Engineering & MIS*, vol. 68, pp. 1-10, 2021.
- [14] S. C. Hsia, J. J. Ciou, and S. Y. Lai, "Multi-channel LED driver with PWM dimming and temperature self-protection," *Proceedings - 2013 9th International Conference on Intelligent Information Hiding and Multimedia Signal Processing, IHH-MSP 2013*, pp. 100–103, 2013.
- [15] K. L. Chen, H. P. Chan, Y. C. Hung, and S. H. Shieh, "A smart LED lighting with multiple dimming and temperature automatic protection capabilities," *Proc. - 2016 IEEE Int. Symp. Comput. Consum. Control. IS3C 2016*, no. 1, pp. 614–617, 2016.
- [16] S. Mishra, S. Gupta, S. Singh, T. Tiwari, A. Mohan, and A. Kushwaha, "Arduino based LED street light auto intensity control system," *Int. J. Adv. Res. Eng. Technol. Sci.*, vol. 3, no. 4, pp. 73–77, 2016.
- [17] R. Husin, S. A. M. Al Junid, and Z. A. Majid, "Automatic Street Lighting System for Energy Efficiency based on low cost Microcontroller," *Int. J. Simul. Syst. Sci. Technol.*, vol. 13, no. 1, pp. 29–34, 2012.
- [18] F. Zafar, D. Karunatilaka, and R. Parthiban, "Dimming schemes for visible light communication: The state of research," *IEEE Wireless Communications*, vol. 22, no. 2, pp. 29–35, 2015.