

Original Research Paper

Voltage Optimization on Low Voltage Distribution Transformer Zones Using Batteries in Uganda

Kelechi Edema Simon Iddi¹, Kalyankolo Umaru², Val Hyginus Udoka Eze^{3*},
Salama Asikuru², Nassaga Musa², Noah Ochima²

¹ Department of Electrical and Control, International University of East Africa, Kampala, Uganda.

² Department of Electrical Engineering and Automation, Muni University, Uganda.

³ Department of Electrical, Telecommunication and Computer Engineering, Kampala International University, Uganda.

Article History

Received:
11.02.2024

Revised:
27.02.2024

Accepted:
07.03.2024

*Corresponding Author:

Val Hyginus Udoka Eze

Email:
udoka.eze@kiu.ac.ug

This is an open access article,
licensed under: [CC-BY-SA](https://creativecommons.org/licenses/by-sa/4.0/)



Abstract: In the context of Uganda's rapidly growing energy demands and the need for sustainable solutions, this study explores the implementation of voltage optimization techniques in Low Voltage (LV) distribution transformer zones. The research focuses on the innovative integration of batteries to optimize voltage levels, thereby enhancing the efficiency and reliability of the electrical distribution system. By analyzing real-time data from various LV transformer zones in Uganda, this study investigates the impact of voltage fluctuations on the overall power distribution network. The research methodology involves the design and deployment of battery energy storage systems (BESS) strategically placed within LV distribution transformer zones. These BESS units are utilized to store excess energy during periods of low demand and release it during peak hours, ensuring consistent voltage levels and minimizing losses in the distribution network. The study evaluates the effectiveness of this approach through extensive simulations and on-site experiments, considering factors such as battery capacity, charging/discharging rates, and load variations. A comprehensive cost-benefit analysis is conducted to evaluate the potential financial savings and environmental impact associated with this sustainable energy solution. The findings of this research indicate significant improvements in voltage regulation, reduced system losses, and enhanced reliability in LV distribution transformer zones. Additionally, the study demonstrates the feasibility of integrating batteries into the existing infrastructure, thereby contributing to the optimization of the energy distribution system in Uganda. The outcomes of this research provide valuable insights for policymakers, utility companies, and researchers, emphasizing the importance of embracing innovative technologies to address the energy challenges faced by developing nations like Uganda.

Keywords: Battery Energy Storage Systems, Energy Efficiency, Environmental Impact, Low Voltage Distribution Transformers, Voltage Optimization.



1. Introduction

Nestled in the heart of Africa, Uganda is a land of vibrant cultures, breathtaking landscapes, and a resilient spirit that defines its people. Amidst this rich tapestry, a silent revolution is taking place, one that is electrifying not just homes but also the future of energy management. In the pursuit of sustainable energy solutions, Uganda is charting a pioneering path by exploring the integration of advanced technology and traditional wisdom. At the forefront of this movement is the remarkable endeavour to optimize voltage on Low Voltage (LV) Distribution Transformer Zones, an initiative that is lighting up lives and illuminating possibilities [1].

In this fascinating journey towards a greener and more efficient energy ecosystem, the marriage of cutting-edge technology and the power of nature's energy storage—batteries—has emerged as a beacon of hope. Voltage optimization, a concept once confined to engineering textbooks, has transformed into a practical reality, breathing life into the LV Distribution Transformer Zones that power communities across Uganda [2]. Just imagine a future where every electron is cherished, where power is not just a commodity but a conscientious choice. In this new narrative, batteries play a pivotal role, not merely as energy storage devices but as catalysts for change [3][4]. They bridge the gap between energy demand and supply, ensuring a seamless flow of power while minimizing wastage. Through this intricate dance of electrons and innovation, Uganda's energy landscape is being reshaped, promising a more reliable and sustainable tomorrow.

This enchanting exploration of Voltage Optimization on LV Distribution Transformer Zones Using Batteries in Uganda is so paramount. This will help researchers discover the synergy between tradition and technology, witness the ingenuity of Ugandan engineers, and explore the limitless possibilities that lie ahead. The increasing energy demand in Uganda has led to an 18.3% increase in the number of new connections, however, these new customers are being added to the already existing networks and this has caused most areas to experience low voltages below -6% according to the Grid code especially during the Peak hours hence causes Dim lights and failure of most equipment [5][6]. Furthermore, during peak periods of electricity demand, losses rise to around 20% and some of these losses are made up through additional generation, Commercial losses to the Utility Company also greatly increase as customers are not utilizing the power when experiencing these very low voltages.

Currently, many efforts are being embarked on to optimize the grid and simultaneously improve electric reliability and reduce energy losses, thus, this research paper is birthed within this background [7]. Battery technology in Uganda is being used on photovoltaic distribution units for solar rural electrification and as of 2002, the government of Uganda approved a renewable energy policy to increase the use of modern renewable energy from 4% to 6% of total energy consumption [8][9][10][11]. As a result, the Electricity Regulatory Authority (ERA) has commissioned over 4 solar grids with recent battery technology each capable of generating approximately 10MW. Therefore, this research article presents a promising solution through the use of battery storage, where energy from the grid is used to charge the battery during off-peak hours, and discharged to supply the load during peak hours. This is called peak shaving, and would both relieve the grid of stress and help improve the voltage quality [12][13]. This study quantifies the impact of batteries on voltage optimization in transformer zones within the grid. The research adhered to ethical guidelines and research policies outlined in Uganda

2. Literature Review

Energy demand, Battery Energy Storage System (BESS) and its integration with the power system LV networks, together with the different types of Batteries and their characteristics from different scholars will be reviewed, analyzed and compared for effective understanding. A researcher in [14] discussed the application of Battery Storage in low-voltage Distribution networks for improving integration of Distributed generation. Energy stored in the battery can be used to cover peak load demand in the evening when there is no electricity generation from the power plants.

Energy storage systems play a vital role in optimizing voltage on low-voltage distribution transformer zones using batteries in countries like Uganda. Uganda, like many other developing nations, faces challenges related to reliable electricity supply and infrastructure constraints. Voltage optimization is crucial in ensuring efficient energy distribution and minimizing losses.

2.1. Energy Storage System

Energy storage system and its functions:

1. Voltage Regulation

Fluctuation Management: Energy storage systems can store excess energy during periods of low demand and release it during peak demand, helping stabilize voltage fluctuations in the distribution network. **Voltage Smoothing:** Batteries can smooth out voltage variations caused by intermittent renewable sources, ensuring a consistent and stable voltage supply to consumers [4][12].

2. Demand Response

Load Shifting: By storing excess energy during off-peak hours, batteries can supply power during peak demand, reducing strain on the distribution system and optimizing voltage levels.

Peak Load Management: Energy storage systems enable utilities to manage high-demand periods effectively, ensuring voltage remains within optimal levels [15].

3. Integration of Renewable Energy

Intermittency Management: Renewable energy sources like solar and wind are intermittent. Batteries store surplus energy generated during high production periods and supply it when production is low, ensuring a steady voltage output to consumers. **Grid Stability:** By providing a buffer against sudden fluctuations in renewable energy generation, batteries enhance grid stability, preventing voltage disturbances [16][17][18].

4. Grid Reliability and Resilience

Backup Power: Energy storage systems serve as backup power sources during grid outages, maintaining voltage levels and preventing damage to sensitive equipment. **Resilience:** Batteries enhance the resilience of the grid by ensuring continuous power supply, even in the face of natural disasters or other emergencies, maintaining voltage stability [19].

5. Reduction of Transmission and Distribution Losses

Peak Shaving: By using stored energy during peak demand, utilities can reduce the need for additional generation capacity, lowering transmission and distribution losses associated with long-distance power transfer. **Efficient Distribution:** Optimized voltage levels lead to reduced losses during distribution, maximizing the efficiency of the entire energy delivery system [15][20]

6. Cost Savings and Economic Benefits

Reduced Infrastructure Investment: Efficient use of energy storage systems can defer the need for building new power plants or expanding grid infrastructure, leading to substantial cost savings. **Energy Arbitrage:** Utilities can buy electricity during low-demand periods when prices are low and store it in batteries, selling it back to the grid during high-demand periods, maximizing profits and optimizing voltage simultaneously [21][22].

Implementing energy storage systems as described can significantly enhance the efficiency and reliability of the low-voltage distribution transformer zones. However, it's important to consider factors such as proper infrastructure, technical expertise, and financial investments to ensure the successful integration of these systems into the existing grid. Collaborative efforts between government bodies, utilities, and technology providers are essential to realizing the full potential of energy storage systems for voltage optimization in Uganda's distribution networks.

2.2. Energy Storage System (Batteries)

The most commonly used energy storage technologies are Lead-acid batteries, Lithium-ion batteries, Nickel-Cadmium batteries, Nickel-Metal Hydride batteries, Flow batteries, Electric Layer Capacitors, etc. The three important factors considered before selecting a battery storage system to be used in this design are (1) the cyclic efficiency of the battery which determines the requirement from the input source. (2) Number of cycles delivered at a specified depth of discharge (3) Lifetime costs and how the battery will be maintained [23].

2.3. Battery Energy Storage System (BESS)

In the context of battery energy storage systems, the design incorporates three essential components: batteries, a Power Conversion System (PCS), and a Battery Management System (BMS). The batteries serve as the energy source, delivering DC power to the PCS. The PCS, in turn, converts the DC power into AC power and utilizes a transformer to adjust the voltage to align with the requirements of the utility and loads. Meanwhile, the BMS functions as the central control unit, managing both the batteries and the PCS, ensuring efficient and reliable operation of the system [14].

2.4. Power Conversion System

A typical Power Conversion System (PCS) employs an Insulated-Gate Bipolar Transistor (IGBT) based DC-to-AC converter connected to a battery. This 4-quadrant PCS can convert utility AC voltage to DC for energy storage or vice versa to release stored energy back to the utility system. The system includes a low pass filter, typically an LCL filter, placed between each phase, designed to mitigate high-frequency harmonics. The LCL filter reduces high-frequency harmonics generated by the Pulse Width Modulation (PWM) conversion technique utilized in the Battery Energy Storage System (BESS). It consists of six IGBTs that switch on and off to convert power between AC and DC. These IGBTs, marked as S1-S6 and controlled by PWM signals from the Battery Management System (BMS), determine the power flow within the inverter [24][25][26]. During battery discharge, when the IGBTs convert DC power to AC power, they create a distinct six-pulse wave pattern.

2.5. Battery Sizing

The battery was sized depending on the exceeding demand from the transformer capacity. This design was based on these parameters:

- Transformer Size = 315KVA
- Maximum Demand = 329.53KVA
- Excess Demand = $329.53 - 315 = 14.53\text{kva}$
- Considering a Power factor = 0.9
- Battery Size = $14.53 \times 0.9 = 13.08\text{ kW}$

Since a single transformer circuit was being considered Battery size was considered to be 10kw to avoid Oversizing.

3. Methodology

3.1. Design

Figure 1 is the block diagram of the system. It consists of a static load flow model constructed in the electrical network modelling software Digisilent (Power Factory 15.1). The second was a dynamic (time-based) simulation developed in MATLAB/SIMULINK. By comparing the performance of the dynamic model to that of the base static load flow, the accuracy of the dynamic model was confirmed.

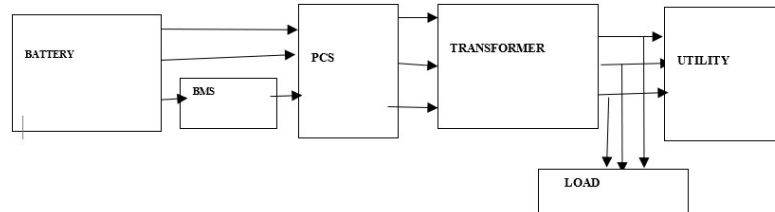

Figure 1. Block Diagram of BESS Model

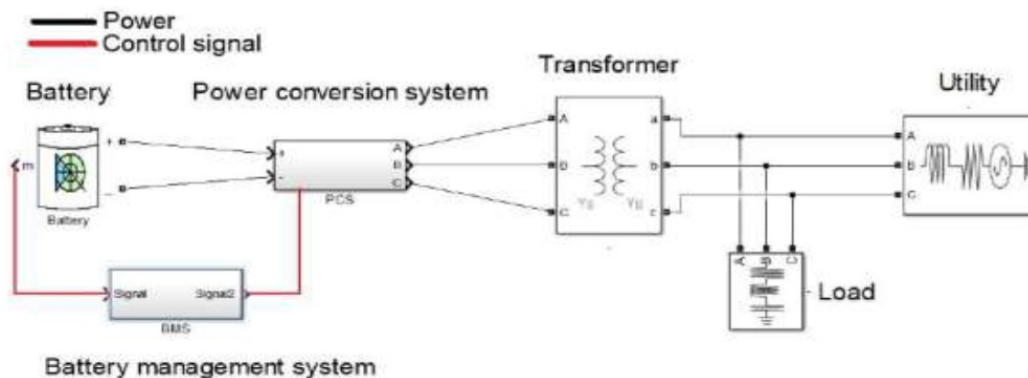

Figure 2. Battery Energy Storage System (BESS)

Battery Energy Storage Systems (BESS) optimize voltage in low-voltage distribution transformer zones by storing excess energy during periods of low demand and releasing it during peak demand. BESS helps maintain a stable voltage profile by dynamically adjusting charge and discharge rates. When voltage levels drop, the system discharges stored energy, alleviating stress on transformers. Conversely, during surplus voltage, it absorbs excess energy. This voltage optimization enhances grid reliability, reduces losses, and supports efficient energy distribution.

From Figure 2, BESS acts as a dynamic buffer, mitigating fluctuations and contributing to a more resilient and balanced low-voltage distribution system.

Figure 3 is a Complete Power Conversion System (PCS) for Voltage Optimization on Low Voltage Distribution Transformer Zones with Batteries. PCS operates by integrating energy storage systems with transformers thereby charging the battery with the excess power generated during periods of low peak and high demand, stored energy is discharged to stabilize voltage, enhancing grid efficiency. The PCS monitors voltage levels, adjusts power flow, and ensures optimal distribution. This designed intelligent system contributes to grid stability, reduces losses, and supports renewable energy integration, fostering a more resilient and efficient power infrastructure.

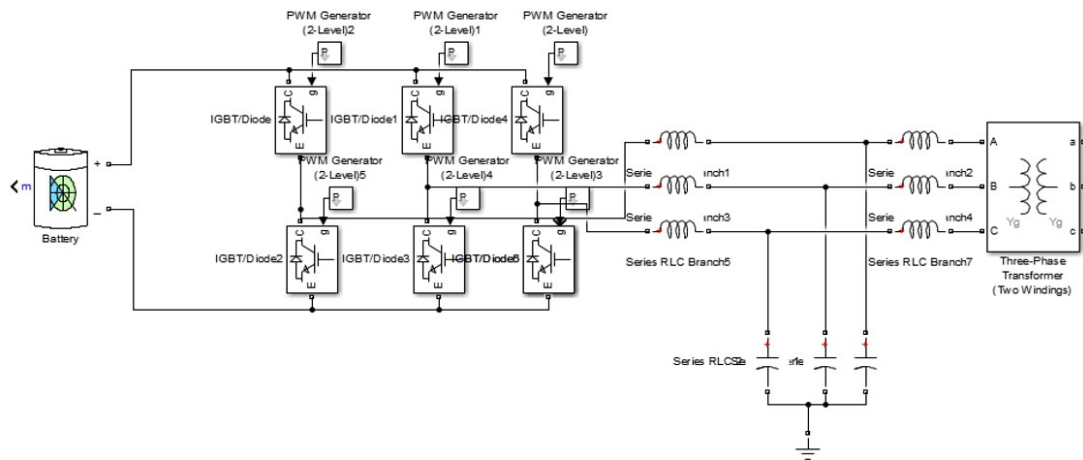

Figure 3. Complete Power Conversion System

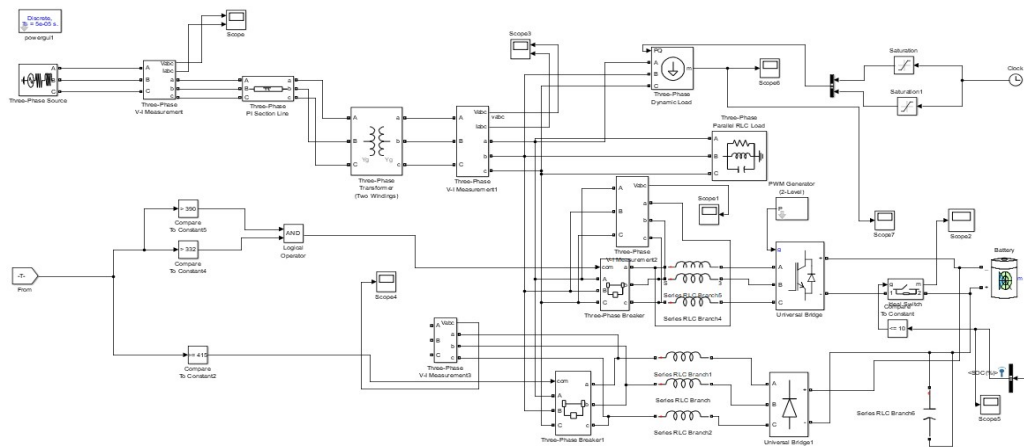

Figure 4. Detailed BESS Simulink Model

Figure 4 is the Detailed Battery Energy Storage System (BESS) Simulink model for Voltage Optimization on Low Voltage Distribution Transformer Zones that employs advanced control algorithms to enhance grid performance. Utilizing batteries, it dynamically regulates voltage levels, mitigating issues in distribution transformer zones. The Simulink model intricately captures the interplay of power electronics, battery dynamics, and grid parameters, providing a comprehensive simulation environment. This model facilitates in-depth analysis and optimization of voltage control strategies, contributing to the efficient integration of battery systems for voltage management in low-voltage distribution networks.

3.2. Simulations

The purpose of the simulation was to investigate the functionality of the BESS charge and discharge process, focusing on the study of the battery state of charge (SOC) were examined to reveal the charging and discharging rates, where an increase indicates charging and a decrease indicates discharging.

Figure 5 is a scenario without a Battery Energy Storage System, the grid was modelled, and simulations were conducted to acquire voltage values for the low-voltage transformer line under peak conditions, representing the worst operating conditions [10].

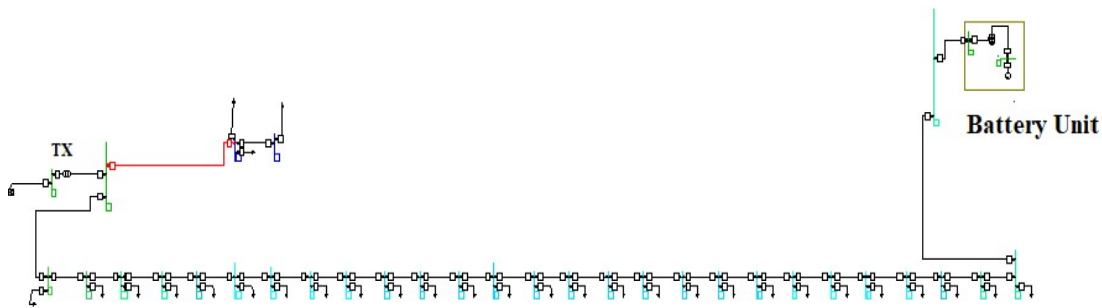

Figure 5. Transformer Circuit Model of Craleno TC as built in the Digisilent Software Environment Without Battery

The grid was configured with a Battery Energy Storage System (BESS), and a simulation was conducted to determine voltage values during Peak Demand as shown in Figure 6. The subsequent simulation assessed the impact of the BESS on voltage quality, specifically examining the frequency and voltage deviation of the Transformer circuit.

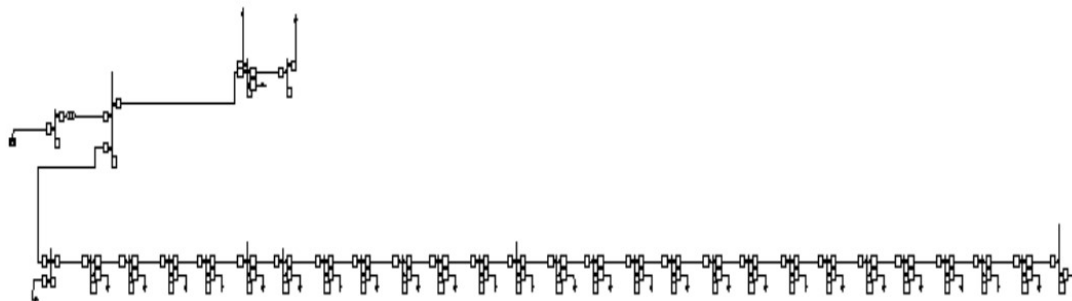

Figure 6. Transformer Circuit Model of Craleno TC as built in the Digisilent software with a Battery System.

4. Finding and Discussion

Understanding and analyzing the characteristics of the SOC graph is essential for effective voltage optimization and management of low-voltage distribution transformer zones using batteries. It allows operators to make informed decisions to maximize efficiency, reduce costs, and ensure the reliability of the electrical system.

Table 1 is the table area of study and the specifications of the materials used to achieve these results.

Table 1. Case Study Area Details

Case Study Area Details	
Transformer name	Craleno TC
Transformer size	315 KVA
Maximum demand	329.53 KVA
Number of customers	121
KVA per customers	2.72KVA
Loading factor	114.765

The State of Charge (SOC) of Voltage Optimization on Low Voltage Distribution Transformer Zones using batteries is a crucial aspect of managing and optimizing the performance of the electrical system. Figure 7 illustrates the battery's energy level during charging in Voltage Optimization on Low Voltage Distribution Transformer Zones. This graph shows the efficient utilization of batteries by displaying voltage trends with respect to time. Optimal charging is reflected by a gradual SOC increase, avoiding overcharging. Voltage was optimized by maintaining SOC within a specified range, enhancing battery lifespan and distribution transformer efficiency. This Strategic design minimizes voltage fluctuations, ensures stability, and optimizes energy transfer in low-voltage zones, thereby enhancing the overall performance of the system.

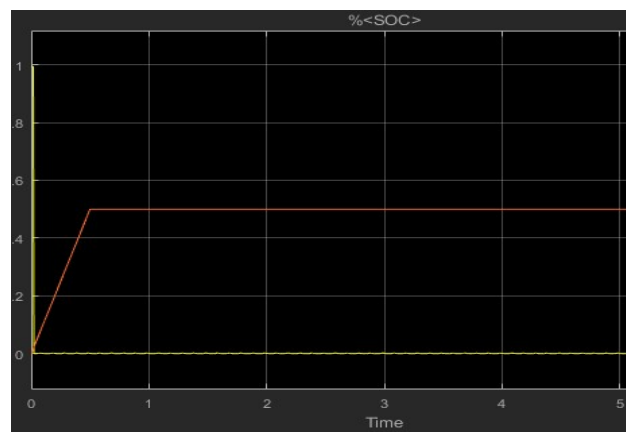

Figure 7. Graph of Charge Rate (Voltage vs Time)

Figure 8 is the State of Charge (SOC) graph in Voltage Optimization on Low Voltage Distribution Transformer Zones Using Batteries depicts, the battery's remaining capacity during discharge. As the battery releases energy, SOC decreases, reflecting the utilized power. Voltage optimization aims to maintain optimal voltage levels, enhancing efficiency. Monitoring SOC ensures efficient battery utilization, preventing over-discharge, and contributes to effective voltage management, crucial for optimizing low voltage distribution transformer zones. The graph's characteristics provide insights into battery performance, guiding strategies to balance discharge for prolonged battery life while optimizing voltage within the distribution network.

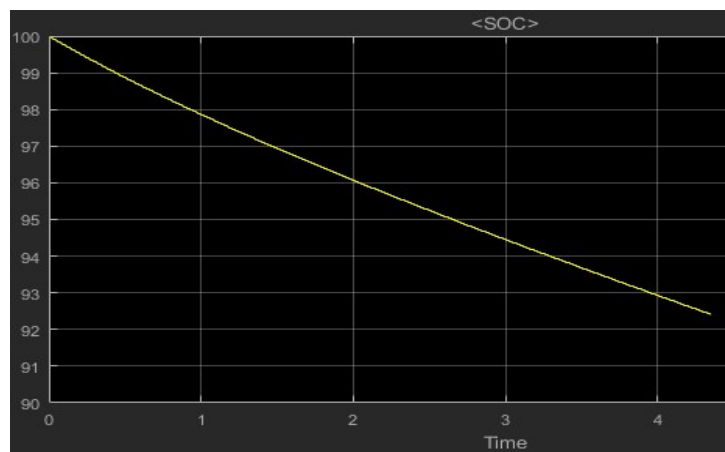

Figure 8. Discharging Rate

5. Conclusion

In conclusion, implementing voltage optimization through battery integration in low-voltage distribution transformer zones proves to be a promising strategy for enhancing energy efficiency in Uganda. This innovative approach not only stabilizes voltage levels but also contributes to a more reliable and sustainable power infrastructure. The integration of batteries presents a viable solution to address voltage fluctuations, ultimately improving the overall performance and longevity of the electrical grid in Uganda.

Based on the results, a battery system greatly optimizes voltage, it's relatively cheap and it can also be transferred after the last stage of transformer injection to other transformer areas having Low voltage problems.

It is recommended that Umeme should consider using Battery Energy Storage systems in the interim before transformer injection in an area. It is also necessary to try different control systems for the BESS to see how that will affect the regulation possibilities

References

- [1] N. S. Fakude. Improving Energy Revenue and Security by Employing Smart Distribution Network System for A Voltage Distribution Network for Residential Users in South Africa (*Doctoral dissertation, University of Johannesburg*), 2021
- [2] F. Faugno, Evaluation of investment options in microgrids developed for rural application in Nigeria, 2018
- [3] C. C. Ogbonna, V. H. U. Eze, E. S. Ikechuwu, O. Okafor, O. C. Anichebe, and O. U. Oparaku, "A Comprehensive Review of Artificial Neural Network Techniques Used for Smart Meter-Embedded forecasting System," *IDOSR Journal Of Applied Sciences*, vol. 8, no. 1, pp. 13–24, 2023.M. C.
- [4] Eze, V. H. U. Eze, N. O. Chidebelu, S. A. Ugwu, J. I. Odo, and J. I. Odi, "Novel Passive Negative And Positive Clamper Circuits Design For Electronic Systems," *International Journal of Scientific & Engineering Research*, vol. 8, no. 5, pp. 856–867, 2017
- [5] UMEME, Integrated Annual Report, Kampala: Umeme, 2017
- [6] W. O. Okafor, S. O. Edeagu, V. C. Chijindu, O. N. Iloanusi, and V. H. U. Eze, "A Comprehensive Review on Smart Grid Ecosystem," *IDOSR Journal of Applied Science*, vol. 8, no. 1, pp. 25–63, 2023.
- [7] P. T. Robert Tumwesigye, "Key issues in Uganda's energy sector," International Institute for Environment and Development (UK), 2011
- [8] V. H. U. Eze, U. O. Oparaku, A. S. Ugwu, and C. C. Ogbonna, "A Comprehensive Review on Recent Maximum Power Point Tracking of a Solar Photovoltaic Systems using Intelligent , Non-Intelligent and Hybrid based Techniques," *International Journal of Innovative Science and Research Technology*, vol. 6, no. 5, pp. 456–474, 2021.

- [9] A. Kant, "Uganda's Kabulasoke solar power plant," The Independent, Gomba District, 2018
- [10] V. H. U. Eze, K. Umaru, E. Edozie, R. Nafuna, and N. Yudaya, "The Differences between Single Diode Model and Double Diode Models of a Solar Photovoltaic Cells: Systematic Review," *Journal of Engineering, Technology & Applied Science*, vol. 5, no. 2, pp. 57–66, 2023, doi: 10.36079/lamintang.jetas-0502.541.
- [11] V. H. U. Eze, "Development of Stable and Optimized Bandgap Perovskite Materials for Photovoltaic Applications," *IDOSR Journal of Computer and Applied Science*, vol. 8, no. 1, pp. 44–51, 2023.
- [12] V. H. U. Eze *et al.*, "Effect of Input Current and the Receiver-Transmitter Distance on the Voltage Detected By Infrared Receiver," *International Journal of Scientific & Engineering Research*, vol. 7, no. 10, pp. 642–645, 2016.
- [13] V. H. U. Eze, "Advancing Sustainable Energy Solutions in Uganda: A Comprehensive Exploration for Multi-Source Power Control Design," *IAA Journal of Applied Sciences 11(1):73-86*, vol. 11, no. 1, pp. 73–86, 2024.
- [14] Z. Šimić, D. Topić, M. Dubravac, and G. Knežević, Application of Battery Storage in Low Voltage Distribution Network for Improving Integration of Distributed Generation. In 2022 18th International Conference on the European Energy Market (EEM), pp. 1-6, IEEE, 2022
- [15] M. Zillmann, R. Yan, and T. K. Saha, Regulation of distribution network voltage using dispersed battery storage systems: A case study of a rural network. In 2011 IEEE Power and Energy Society General Meeting (pp. 1-8), 2011
- [16] V. H. U. Eze, E. Edozie, K. Umaru, O. W. Okafor, C. N. Ugwu, and F. C. Ogenyi, "Overview of Renewable Energy Power Generation and Conversion (2015-2023)," *Eurasian Experiment Journal Of Engineering (EEJE)*, vol. 4, no. 1, pp. 105–113, 2023.
- [17] V. H. U. Eze, K. C. A. Uche, W. O. Okafor, E. Edozie, C. N. Ugwu, and F. C. Ogenyi, "Renewable Energy Powered Water System in Uganda: A Critical Review," *Newport International Journal Of Scientific And Experimental Sciences (NIJSES)*, vol. 3, no. 3, pp. 140–147, 2023.
- [18] V. H. U. Eze *et al.*, "A Systematic Review of Renewable Energy Trend," *Newport International Journal Of Engineering And Physical Sciences*, vol. 3, no. 2, pp. 93–99, 2023.
- [19] J. Lindstens, Study of a battery energy storage system in a weak distribution grid, 2017
- [20] V. H. U. Eze, M. C. Eze, V. Chijindu, E. Chidinma E, U. A. Samuel, and O. C. Chibuzo, "Development of Improved Maximum Power Point Tracking Algorithm Based on Balancing Particle Swarm Optimization for Renewable Energy Generation," *IDOSR Journal of Applied Sciences*, vol. 7, no. 1, pp. 12–28, 2022.
- [21] S. Jiang, S. Wen, M. Zhu, Y. Huang, and H. Ye, Scenario-Transformation-Based Optimal Sizing of Hybrid Hydrogen-Battery Storage for Multi-Timescale Islanded Microgrids. *IEEE Transactions on Sustainable Energy*, vol. 99, pp. 1-12, 2023
- [22] V. H. U. Eze, O. N. Iloanusi, M. C. Eze, and C. C. Osuagwu, "Maximum power point tracking technique based on optimized adaptive differential conductance," *Cogent Engineering*, vol. 4, no. 1, p. 1339336, 2017, doi: 10.1080/23311916.2017.1339336.
- [23] G. Fernández, N. Galan, D. Marquina, D. Martínez, A. Sanchez, P. López, ... and J. Rueda, Photovoltaic generation impact analysis in low voltage distribution grids. *Energies*, vol. 13, no. 17, 4347, 2020
- [24] V. H. U. Eze, J. S. Tamball, O. F. Uzoma, I. Sarah, O. Robert, and W. O. Okafor, "Advancements in Energy Efficiency Technologies for Thermal Systems : A Comprehensive Review," *INOSR Applied Sciences*, vol. 12, no. 1, pp. 1–20, 2024.
- [25] V. H. U. Eze, J. S. Tamball, O. Robert, and W. O. Okafor, "Advanced Modeling Approaches for Latent Heat Thermal Energy Storage Systems," *IAA Journal of Applied Sciences 11(1):49-56*, vol. 11, no. 1, pp. 49–56, 2024.
- [26] V. H. U. Eze, J. S. Tamball, O. Robert, and W. O. Okafor, "Advanced Modeling Approaches for Latent Heat Thermal Energy Storage Systems," *IAA Journal of Applied Sciences 11(1):49-56*, vol. 11, no. 1, pp. 49–56, 2024.